

Single high rate CANFD isolation transceiver module in SMD package



RoHS



FEATURES

- Small SMD12 size measuring 17.00*12.14*9.45mm
- Two-port isolation test voltage (2.5kVDC)
- High baud rate up to 5 Mbps
- Operating ambient temperature range: -40°C to +105°C
- The bus supports maximum 110 nodes
- Set isolation and ESD bus protection in one
- EN62368 approval

TD331SCANFD/TD531SCANFD series are single-channel high-rate small-size CANFD (flexible data rate) isolated transceiver modules with an upgraded version of CAN. The main feature of the isolated CAN transceiver is to further enhance its data transmission performance that successfully achieves a data transfer rate of up to 5Mbit/s. Also, they can easily be embedded in the user's end equipment, to achieve fully functional CAN bus network connectivity. The products are using pick and place SMD packaging technology, thus enabling the use of fully automated processing.

Selection Guide

Certification	Part No.	Power Input (VDC)	Baud Rate (bps)	Static Current (mA) (Typ.)	Maximum Operating Current (mA)	Bus Maximum Voltage (VDC)	Number of Nodes
CE	TD331SCANFD	3.3	40k-5M	18	75	±58	110
	TD531SCANFD	5	40k-5M	18	75	±58	110

Absolute Limits

Item	Operating Conditions	Min.	Typ.	Max.	Unit
Input Surge Voltage (1sec.max.)	3.3V series	-0.7	--	5	VDC
	5.0V series	-0.7	--	7	
Reflow Soldering Temperature	Peak temp. ≤245°C, maximum duration ≤60s at 217°C. Please also refer to IPC/JEDEC J-STD-020D.1.				

3.3V Input Specifications

Item	Symbol	Min.	Typ.	Max.	Unit
Power Supply Input Voltage	VCC	3.15	3.3	3.45	VDC
TXD Logic Level	High-level	V _{IH}	--	V _{CC}	
	Low-level	V _{IL}	0	0.3V _{CC}	
RXD Logic Level	High-level	V _{OH}	3.1	--	
	Low-level	V _{OL}	0	0.4	
TXD Drive Current	I _T	2	--	--	mA
RXD Output Current	I _R	--	--	10	
Serial Interface	Standard CAN controller interface for +3.3V				

5.0V Input Specifications

Item	Symbol	Min.	Typ.	Max.	Unit
Power Supply Input Voltage	VCC	4.75	5	5.25	VDC
TXD Logic Level	High-level	V _{IH}	--	V _{CC}	
	Low-level	V _{IL}	0	0.3V _{CC}	
RXD Logic Level	High-level	V _{OH}	4.8	--	
	Low-level	V _{OL}	0	0.4	
TXD Drive Current	I _T	2	--	--	mA
RXD Output Current	I _R	--	--	10	
Serial Interface	Standard CAN controller interface for +5.0V				

Transmission Specifications

Item	Symbol	Min.	Typ.	Max.	Unit
Data Delay	TXD Transmitter Delay	tr	55	130	ns
	RXD Receiver Delay	tr	65	135	
	Cycle Delay	t _{PRO(TXD-RXD)}	120	250	
Dominant Timeout		--	1.25	5	mS

Output Specifications

Item	Symbol	Min.	Typ.	Max.	Unit	
Dominant Level (Logic 0)	CANH	V _{(OD)CANH}	2.75	3.5	4.5	VDC
	CANL	V _{(OD)CANL}	0.5	1.5	2.25	
Recessive Level (Logic 1)	CANH	V _{(OR)CANH}	2	2.5	3	
	CANL	V _{(OR)CANL}	2	2.5	3	
Differential Level	Dominant Level (Logic 0)	V _{diff(d)}	1.5	2	3	
	Recessive Level (Logic 1)	V _{diff(r)}	-0.05	0	0.05	
Bus Pin Maximum Withstand Voltage	V _x	-58	--	+58		
Bus Transient Toltage	V _{trt} , Meets ISO7637-3 standard	-150	--	+100		
Bus Pin Leakage Current	(VCC=0V, V _{CANH/L} =5V)	-5	--	5	uA	
Load Resistance Differential	R _L	45	60	65	Ω	
Input Impedance Differential	R _{diff}	19	30	52	kΩ	
CAN Bus Interface	Meets ISO/DIS 11898-2 standard Twisted-pair output					

General Specifications

Item	Operating Conditions	Value
Isolation Test	Electric strength test for 1 min., leakage current <1mA	2.5 kVDC
Insulation Resistance	At 500VDC	1000MΩ (input-output)
Operating Temperature		-40°C to +105°C
Transportation and Storage Temperature		-50°C to +125°C
Operating Humidity	Non-condensing	10% - 90%
Safety Standard		EN62368
Safety Certification		EN62368
Safety Class		CLASS III

Mechanical Specifications

Case Material	WH9100-F (UL94 V-0)
Package	SMD12; Dimension 17.00 x 12.14 x 9.45mm
Weight	2.8g (Typ.)
Cooling Method	Free air convection

Electromagnetic Compatibility (EMC)

Emission	CE	CISPR32/EN55032	CLASS A (see Fig.3)	
Immunity	ESD	IEC/EN 61000-4-2	Contact ± 4kV/Air ± 8kV (without external components, signal port)	Perf. Criteria B
	RS	IEC/EN 61000-4-3	10V/m (without external components)	Perf. Criteria A
	EFT	IEC/EN 61000-4-4	±2kV (without external components, signal port)	Perf. Criteria B
	Surge	IEC/EN 61000-4-5	±2kV (line to ground) (without external components, signal port)	Perf. Criteria B
	CS	IEC/EN 61000-4-6	3Vr.m.s (without external components)	Perf. Criteria A

Application Precautions

1. Carefully read and follow the instructions before use; contact our technical support if you have any question;
2. Do not use the product in hazardous areas;
3. Use only DC power supply source for this product. 220V AC power supply is prohibited;
4. It is strictly forbidden to disassemble the product privately in order to avoid product failure or malfunction;
5. Hot-swap is not supported.

After-sales service

1. Factory inspection and quality control are strictly enforced before shipping any product; please contact your local representative or our technical support if you experience any abnormal operation or possible failure of the module;
2. The products have a 3-year warranty period, from the date of shipment. The product will be repaired or exchanged free of charge within the warranty period for any quality problem that occurs under normal use.

Applied circuit

Refer to the CAN Industrial Bus Interface Isolating Module Application Manual.

Design Reference

1. Typical application circuit

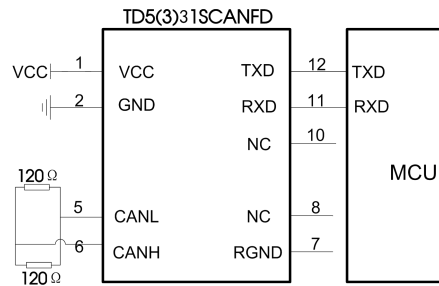

Fig. 1

2. Recommended port protection circuit

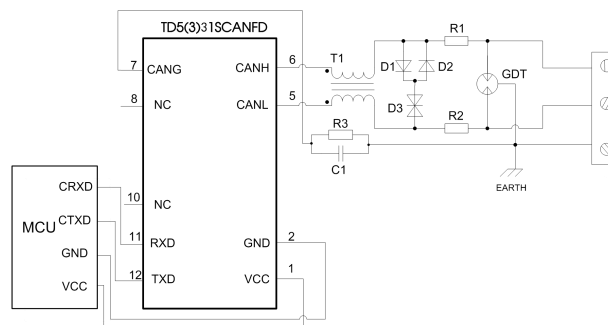

Fig. 2

Note: Ground shield of twisted wire pair reliably.

Recommended components and values:

Component	Recommended part, value	Component	Recommended part, value
R3	1M Ω	R1, R2	2.7 Ω /2W
C1	1nF, 2kV	D1, D2	1N4007
T1	ACM2520-301-2P	D3	SMBJ15CA
GDT	B3D090L		

When the module is used in applications with harsh environment, it can be susceptible to large energy like lightning strike, etc. in which case, it is essential to add an adequate protection circuit to the CANFD signal ports to protect the system from failure and maintain a reliable bus communication. Figure 2 provides a recommended protection circuit design for high-energy lightning surges, with a degree of protection related to the selected protection device. Parameter description lists a set of recommended circuit parameters, which can be adjusted according to the actual application situation. Also, when using the shielded cable, the reliable single-point grounding of the shield must be achieved.

Note: The recommended components and values is a general guideline only and must be verified for the actual user's application. We recommended using PTC's for R1 and R2 and to use fast recovery diodes for D1 and D2.

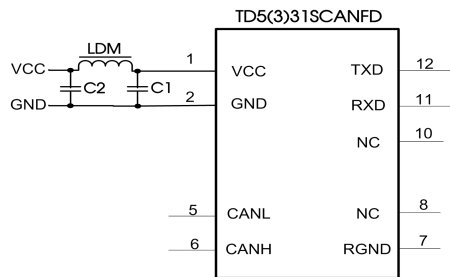

Component	Recommended part, value
C1, C2	1uF/16V
LDM	CD43-12uH

Fig.3

3. For additional information, please refer to our application note on www.mornsun-power.com

Dimensions and Recommended Layout

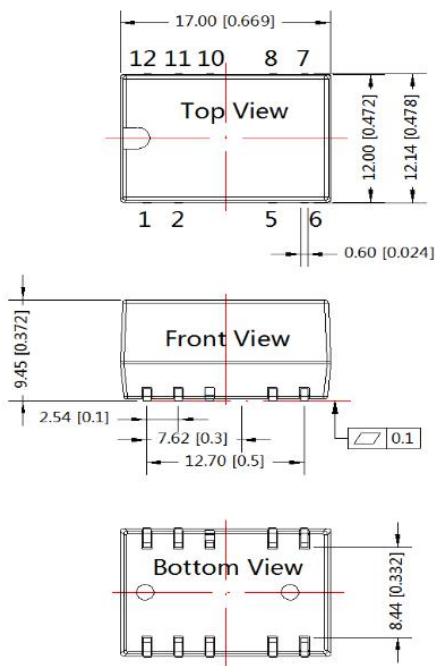

Note:
Unit: mm[inch]
Pin section tolerances: $\pm 0.10[\pm 0.004]$
General tolerances: $\pm 0.25[\pm 0.010]$

THIRD ANGLE PROJECTION

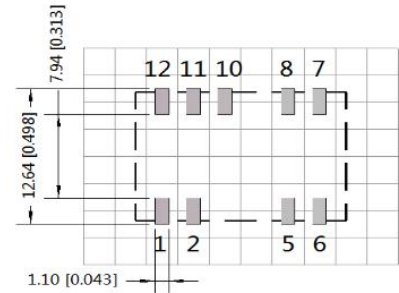
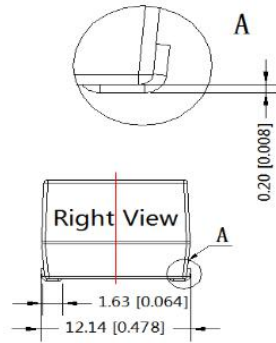

Note: Grid 2.54*2.54mm

Pin-Out		
Pin	Name	Function
1	VCC	Input Power+
2	GND	GND
5	CANL	CANL Pin
6	CANH	CANH Pin
7	CANG	Isolation Power Output Ground
8	NC	No Functon
10	NC	No Functon
11	RXD	Receiving Pin
12	TXD	Sending Pin

NC: Pin to be isolated from circuitry

Package diagram:

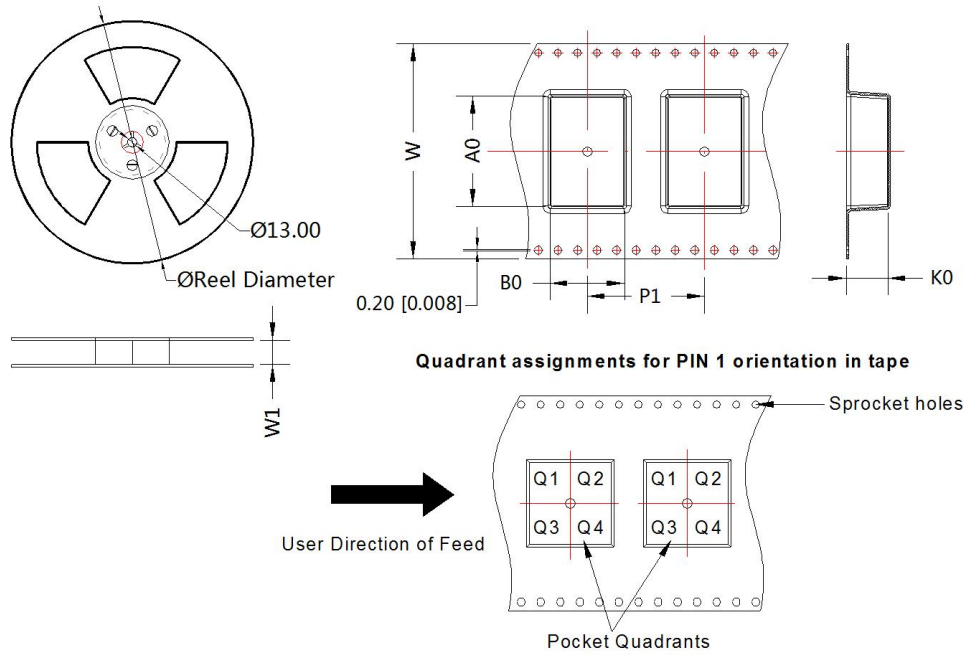

Device	Package Type	Pin	SPQ	Reel Diameter (mm)	Reel Width W1 (mm)	A0 (mm)	B0 (mm)	K0 (mm)	P1 (mm)	W (mm)	Pin1 Quadrant
TDx31SCANH	SMD	9	300	330.0	32.5	17.72	12.92	10.5	20.0	32.0	Q1
TDx31SCANFD	SMD	9	300	330.0	32.5	17.72	12.92	10.5	20.0	32.0	Q1

Notes:

1. For additional information on Product Packaging please refer to www.mornsun-power.com. The Tube Packaging bag number: 58240014; The Roll Packaging bag number: 58240013;
2. Unless otherwise specified, parameters in this datasheet were measured under the conditions of $T_a=25^{\circ}\text{C}$, humidity<75%RH with nominal input voltage and rated output load;
3. All index testing methods in this datasheet are based on company corporate standards;
4. The above are the performance indicators of the product models listed in this datasheet. Some indicators of non-standard models will exceed the above requirements. For details, please contact our technical staff;
5. We can provide product customization service, please contact our technicians directly for specific information;
6. Products are related to laws and regulations: see "Features" and "EMC";
7. Our products shall be classified according to ISO14001 and related environmental laws and regulations, and shall be handled by qualified units.

MORNSUN Guangzhou Science & Technology Co., Ltd.

Address: No. 5, Kehui St. 1, Kehui Development Center, Science Ave., Guangzhou Science City, Huangpu District, Guangzhou, P. R. China
Tel: 86-20-38601850 Fax: 86-20-38601272 E-mail: info@mornsun.cn www.mornsun-power.com